

# LNG



## TANKS AND CRYOGENIC EQUIPMENT FOR LIQUIFIED NATURAL GAS AND OTHER GASES AT CRYOGENIC PRESSURE AND TEMPERATURE



STATIC TANKS

TANKS FOR SERVICE STATIONS

ISO-CONTAINERS

SKIDS

TANKERS FOR TRANSPORT

# Tanks for LNG

Engineering,  
development  
and  
manufacture  
of tanks for  
your projects  
of pressurized  
liquefied  
natural gas  
at cryogenic  
temperature.



**PT LINTECH DUTA  
PRATAMA**

Office/Workshop : Wira Jatim  
Industrial Estate, Mastrip 70,  
Karangpilang, Surabaya,  
Indonesia 60221  
Lintech Seaside Facility:  
Daendels Street, Paciran Cape  
Lamongan , 74 km from  
Surabaya, Indonesia  
Phone: +62-31-7666 891 Fax:  
+62-31-7664 604  
E-MAIL : [admin@lintech.co.id](mailto:admin@lintech.co.id)  
WEBSITE:  
<http://www.lintech.co.id> ;  
<http://www.lsf.co.id>



# INDEX

PAGE

## STATIC TANKS FOR LNG STORAGE

■ STATIC TANKS HORIZONTAL AND VERTICAL .....	6
■ DIAMETER 2200 .....	8
■ DIAMETER 3000 .....	10
■ DIAMETER 3500 .....	12
■ DIAMETER 3900 .....	14
■ DIAMETER 4200 .....	16
■ DIAMETER 7200 .....	17
■ DIAMETER 6150 (Carrier SHIP) .....	18

## LNG TANKS FOR SERVICE STATIONS

■ CRYOGENIC TANKS FOR VEHICULAR NATURAL GAS LC VNG .....	20
--	----

## ISO-CONTAINERS FOR THE TRANSPORT OF LNG

■ CRYOGENIC TANK-CONTAINER LTCC..* .....	22
--	----

## LNG SKID

■ CRYOGENIC SKID UNIT LCUA 1000 V .....	24
---	----

## LNG TANKERS

■ LTC58 TANKER FOR LNG TRANSPORT AND SUPPLY .....	26
---	----

*Double-wall liquefied natural gas storage tanks with vacuum insulation, comprising two concentric tanks, an inner tank in austenitic stainless steel and an outer tank in carbon steel, protected against weathering by special anti-rust surface treatment.*

The chamber between the two concentric tanks is filled with a material with a high insulating capacity and hygroscopic material is also added. A vacuum ( $< 5 \cdot 10^{-2}$  mbar) is then made in the chamber and this together provides the thermal insulation for the tank.

Lintech standard tanks have capacities ranging from 5 to 850 m<sup>3</sup>, for horizontal and vertical installation and with working pressures of 10 bar (9 bar beginning with D3500) and design temperature -196 +50 °C.

Our tanks are designed and manufactured according to European Directive 2014/68/EU or, upon request, to ASME VIII, div.1. They undergo checking and testing during the manufacturing process in line with Lintech's internal quality standards and EN ISO 9001 certification as well as being supervised by independent quality entities.

All of our cryogenic tanks are supplied with the valve fittings mounted, including a PBU pressure build up unit that maintains the tank's operating pressure in normal working conditions.

This documentation describes the equipment supplied for standard "LINTECH" LNG tanks.

We adapt the tank and equipment design to other design pressures or cryogenic fluids, or to the specific requirements from the project or from our clients.

Static tanks specifically for LNG service stations, tankers for LNG transport, handling and service, LNG skids and ISO-containers for maritime and land transport of LNG complete the range of CRYOGENIC TANKS AND EQUIPMENT described in this catalogue.



## QUALITY IN CRYOGENIC TANKS FOR LNG

Quality management and planning together with inspections throughout the whole of the manufacturing process of **lapesa** products is an essential part our corporate strategy and a responsibility that is taken on at all levels of the company. Our permanent objective is centred on continually improving the efficiency of our quality management in order to achieve the highest standards of quality in all of our products.

**LINTECH** boasts **ISO 9001** quality certification since 1998, and manufactures its products in accordance with the European standards and directives on the manufacture of pressurized vessels in general and specifically that referring to tanks for gases at cryogenic temperature, with **EC marking**.

Also in compliance with **US ASME VIII, div.1, standards** and **“U” marking** (ASME stamp).

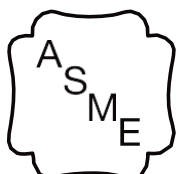

### GENERAL CHARACTERISTICS

- **MAXIMUM DESIGN PRESSURE:**  
10 bar (9 bar beginning with D3500). For other design pressures please consult.
- **MINIMUM DESIGN TEMPERATURE:** -196 °C.
- **NORMS:**  
European Pressure Equipment Directive (PED) 2014/68/UE.  
Spanish norms for pressure tanks.  
Spanish norms for LNG storage.
- **MAIN MATERIALS:**  
Inner tank: austenitic stainless steel.  
Outer tank: carbon steel.  
Pipes in contact with LNG: austenitic stainless steel (SCH 40).
- **INSULATION:**  
Perlite in vacuum atmosphere (absolute pressure  $<5 \cdot 10^{-2}$  mbar).
- **FINISHING:**



## EQUIPMENT INCLUDED

- Vent pipe with flame arrester, orientable from valves zone.
- Sensor for vacuum measurement type “Teledyne”.
- Unified filling connection DN50.
- Electronic level by differential pressure brand SAM.
- Pressure Build Up System (PBU) made of aluminum
- Pressure relief system with manifold.
- Manual cryogenic stopvalves with extended spind

## OPTIONAL EQUIPMENT

- Different design pressures.
- SPECIAL NORMS: local norms, ASME code (with stamp), EN, ISO, ...
- Internal economizer.
- Kit economizer for external installation (regulator + filter + stopvalve).
- Inner tank resistant to vacuum.
- Mechanical level by differential pressure, brand WII
- Several PBU sizes for different consumption needs
- Piloted stopvalves.
- Multilayer insulation.
- Different valve brands.
- Double filling valve.
- Double overflow valve.
- Double level indicator.

### EXAMPLE LINTECH LNG TANKS DENOMINATION:

LC6H22

LINTECH cryogenic tank 6  
- nominal volume 6 m<sup>3</sup>H -  
horizontal installation 22 -  
diameter 2.200 mm



## DIAMETER 2200

HORIZONTAL MODELS		LC5H22	LC6H22	LC11H22	LC16H22	LC20H22
Nominal volume	m <sup>3</sup>	5	6	11	16	20
Theoretical volume	m <sup>3</sup>	5,0	6,2	11,0	15,7	19,9
Usable capacity <sup>(1)</sup>	Tm	2,2	2,7	4,8	6,9	8,7
Length (A)	mm	2.963	3.463	5.463	7.463	9.243
Distance between supports (B)	mm	1.000	1.500	3.500	5.500	7.300
Theoretical tare (Tn)	Tm	2,2	2,6	3,9	5,2	7,0

VERTICAL MODELS		LC5V22	LC6V22	LC11V22	LC16V22	LC20V22
Nominal volume	m <sup>3</sup>	5	6	11	16	20
Theoretical volume	m <sup>3</sup>	5,0	6,2	11,0	15,7	19,9
Usable capacity <sup>(1)</sup>	Tm	2,2	2,7	4,8	6,9	8,7
Height (A)	mm	2.963	3.463	5.463	7.463	9.243
Theoretical tare (Tn)	Tm	2,3	2,7	4,1	5,5	7,3

Standard PPR for consumption of 400 Nm<sup>3</sup>/h at 3 bar (other capacities: 1000, 2000, 3000 and 4000 Nm<sup>3</sup>/h)

(1) The indicated usable capacity has been calculated considering the theoretical volume (without cooling), a maximum filling of 95% and a liquid density of 460 kg/m<sup>3</sup>

### SCHEMATIC DIAGRAM

- VG Gas phase filling valve
- VL Liquid phase filling valve
- VC Consumption valve
- VR Overflow valve
- PPR Pressure Build up Unit (PBU)
- VEP Input valve PBU
- VSP Output valve PBU
- VRA Pressure regulator
- F Filter
- VAG Auxiliary valve - Gas phase
- IN Level
- IP Manometer
- vn Level gate valve
- re By-pass valve
- ri Bottom level valve
- rs Top level valve
- TP Pressure transmitter (according to model)
- TN Level transmitter (according to model)
- CS 3-way valve (safety)
- VS Safety valve
- SL Line safety valve
- VA Pressure relief valve
- Pe Casing safety device
- Tv Vacuum connection
- Mv Vacuum gauge device

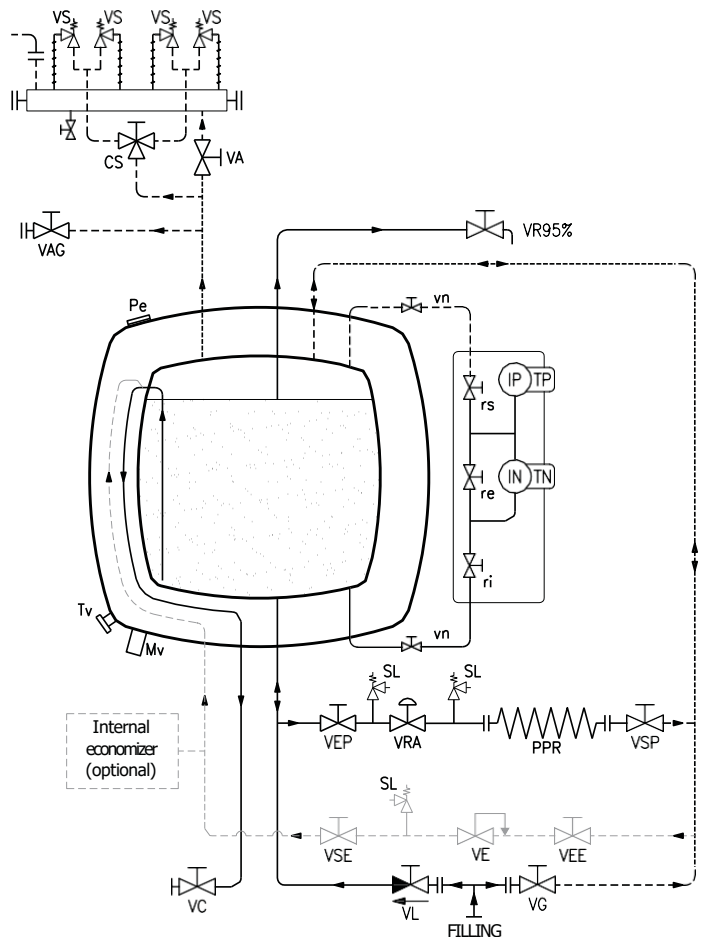

## GENERAL DIMENSIONS

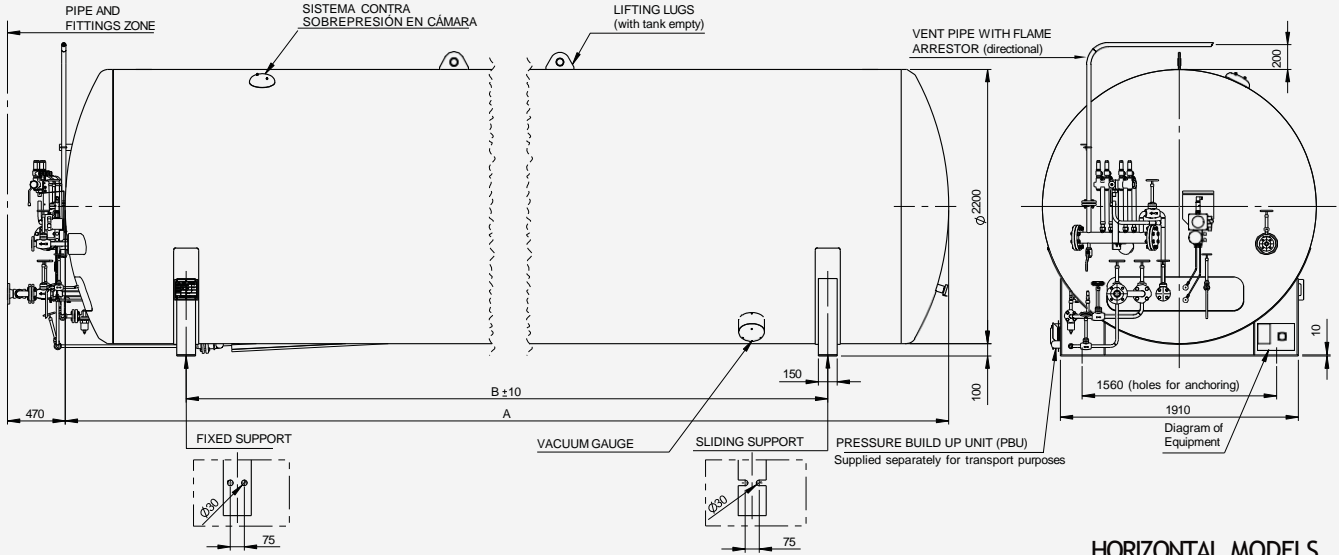

HORIZONTAL MODELS

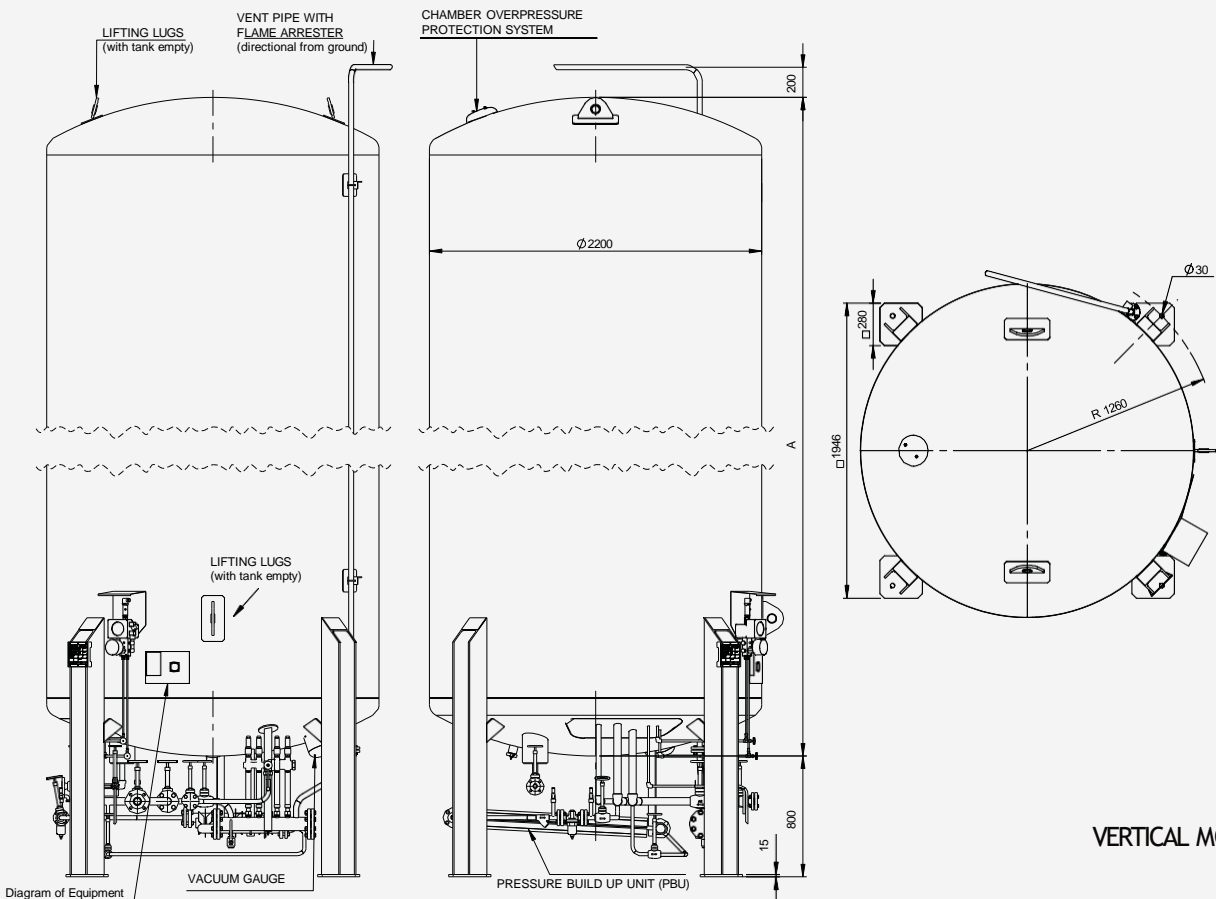

VERTICAL MODELS

## DIAMETER 3000

HORIZONTAL MODELS		LC30H30	LC40H30	LC50H30	LC60H30	LC80H30
Nominal volume	m <sup>3</sup>	30	40	50	60	80
Theoretical volume	m <sup>3</sup>	30,6	40,3	49,9	59,8	79,2
Usable capacity <sup>(1)</sup>	Tm	13,4	17,6	21,8	26,1	34,6
Length (A)	mm	7.374	9.374	11.334	13.374	17.374
Distance between supports (B)	mm	4.800	6.800	8.800	10.800	14.800
Theoretical tare (Tn)	Tm	10,7	13	14,6	17,7	22,5

VERTICAL MODELS		LC30V30	LC40V30	LC50V30	LC60V30	LC80V30
Nominal volume	m <sup>3</sup>	30	40	50	60	80
Theoretical volume	m <sup>3</sup>	30,6	40,3	49,9	59,8	79,2
Usable capacity <sup>(1)</sup>	Tm	13,4	17,6	21,8	26,1	34,6
Height (A)	mm	7.374	9.374	11.334	13.374	17.374
Theoretical tare (Tn)	Tm	11,1	13,5	15,8	18,2	23,2

PPR standard para consumo de 1000 Nm<sup>3</sup>/h a 3 bar (otras capacidades: 2000, 3000 y 4000 Nm<sup>3</sup>/h)

(1) The indicated usable capacity has been calculated considering the theoretical volume (without cooling), a maximum filling of 95% and a liquid density of 460 kg/m<sup>3</sup>

### SCHEMATIC DIAGRAM

- VG Gas phase filling valve
- VL Liquid phase filling valve
- VC Consumption valve
- VR Overflow valve
- PPR Pressure Build up Unit (PBU)
- VEP Input valve PBU
- VSP Output valve PBU
- VRA Pressure regulator
- F Filter
- VAG Auxiliary valve - Gas phase
- IN Level
- IP Manometer
- vn Level gate valve
- re By-pass valve
- ri Bottom level valve
- rs Top level valve
- TP Pressure transmitter (according to model)
- TN Level transmitter (according to model)
- CS 3-way valve (safety)
- VS Safety valve
- SL Line safety valve
- VA Pressure relief valve
- Pe Casing safety device
- Tv Vacuum connection
- Mv Vacuum gauge device

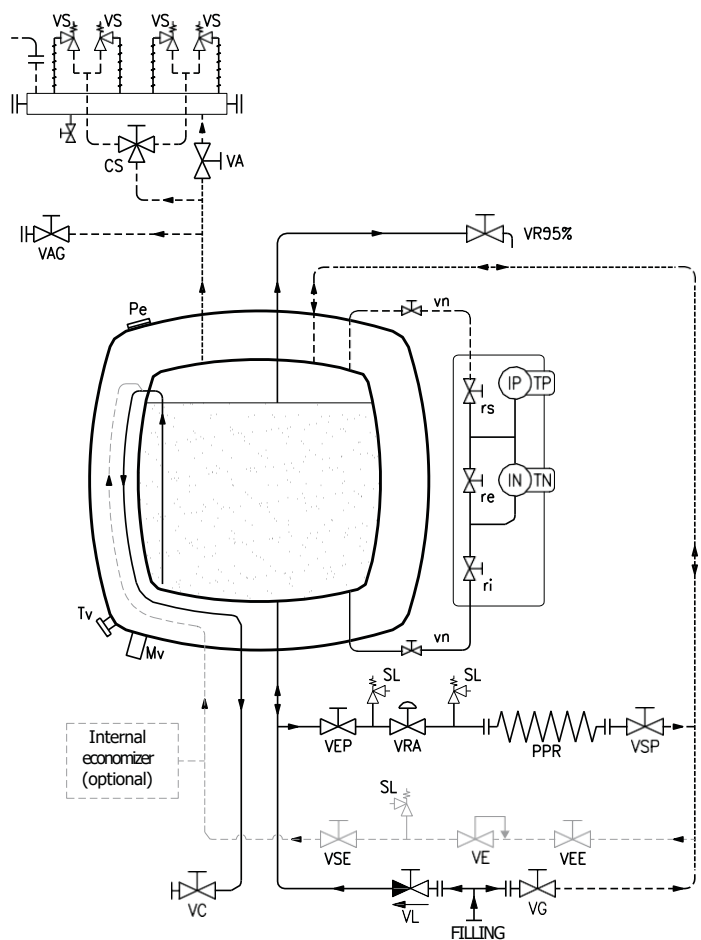

## GENERAL DIMENSIONS

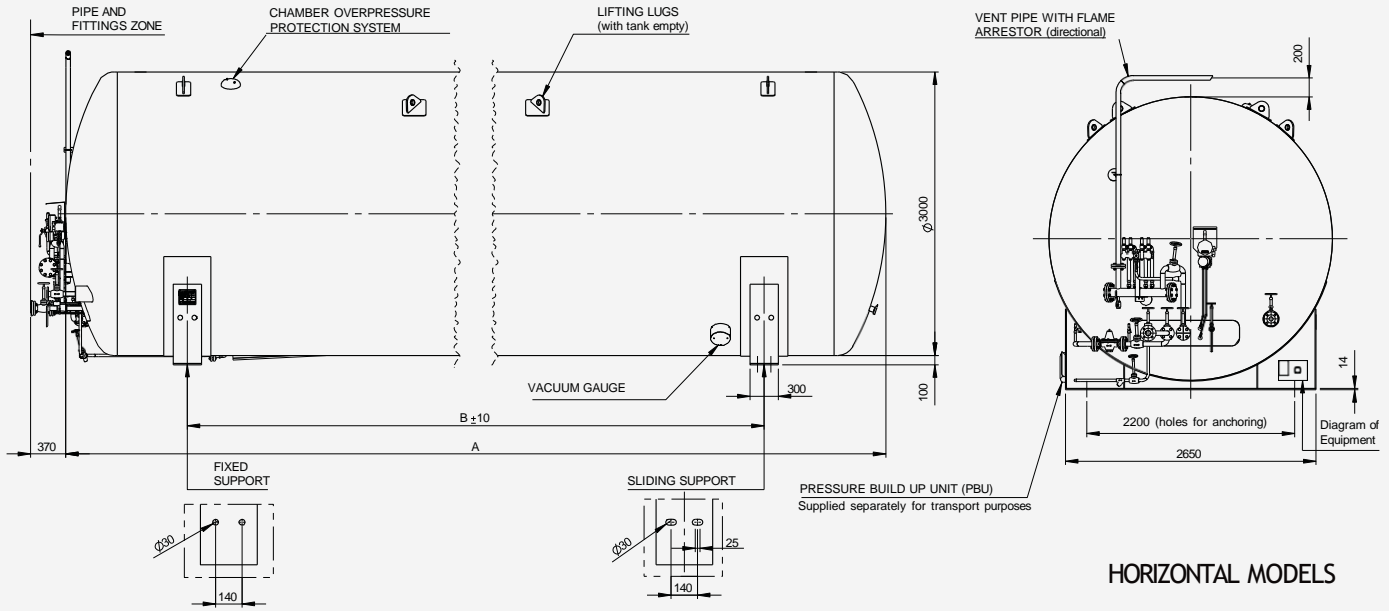

HORIZONTAL MODELS

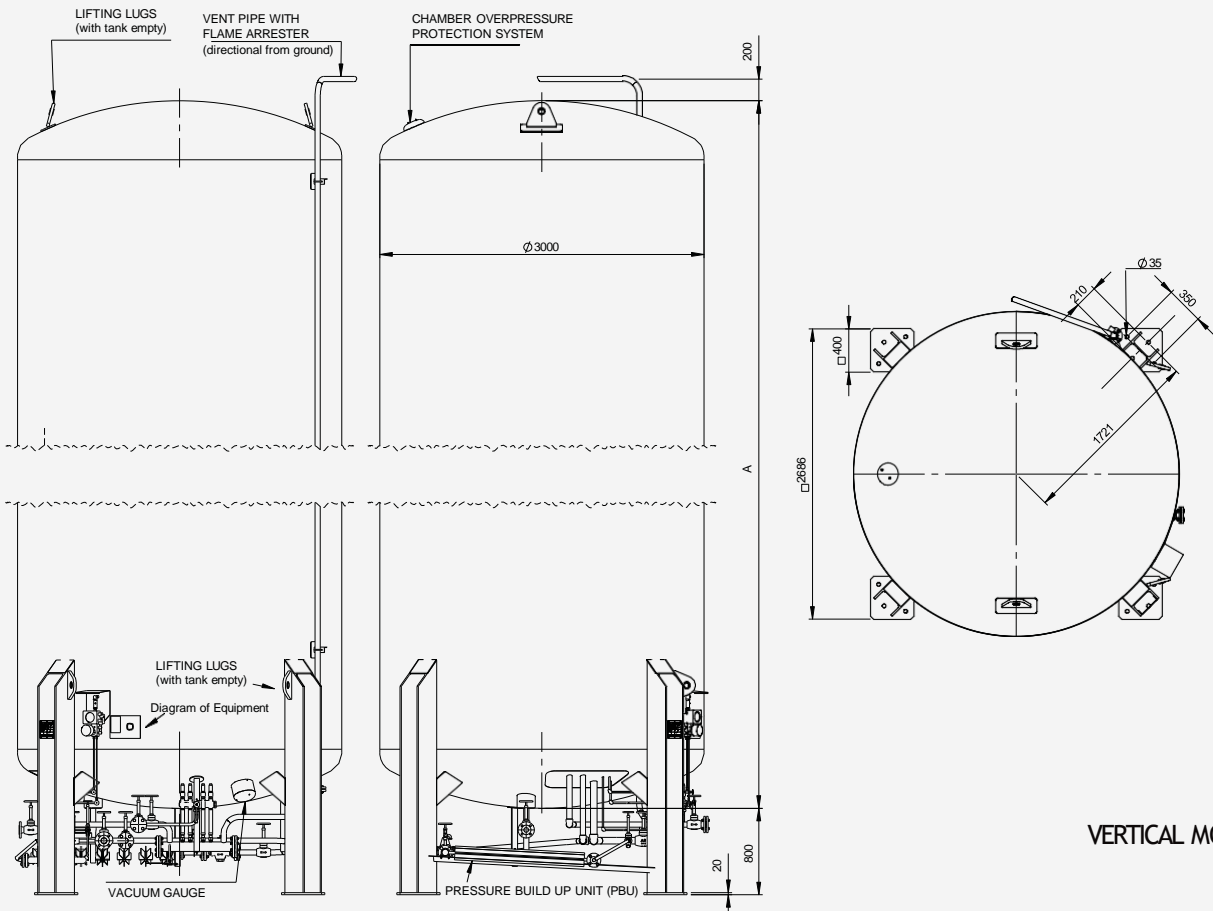

VERTICAL MODELS

## DIAMETER 3500

HORIZONTAL MODELS		LC80H35	LC92H35*	LC106H35	LC120H35
Nominal volume	m <sup>3</sup>	80	92	106	120
Theoretical volume	m <sup>3</sup>	79,9	91,5	105,5	119,5
Usable capacity <sup>(1)</sup>	Tm	34,9	40,0	46,1	52,2
Length (A)	mm	12.547	14.217	16.217	18.217
Distance between supports (B)	mm	9.700	11.400	13.400	15.400
Theoretical tare (Tn)	Tm	19,3	21,8	24,7	27,6

VERTICAL MODELS		LC80V35	LC92V35	LC106V35	LC120V35
Nominal volume	m <sup>3</sup>	80	92	106	120
Theoretical volume	m <sup>3</sup>	79,9	91,6	105,5	119,5
Usable capacity <sup>(1)</sup>	Tm	34,9	40	46,1	52,2
Height (A)	mm	12.467	14.137	16.137	18.117
Theoretical tare (Tn)	Tm	19,6	22,1	25,1	28,1

PPR standard para consumo de 1000 Nm<sup>3</sup>/h a 3 bar (otras capacidades: 2000, 3000 y 4000 Nm<sup>3</sup>/h)

(1) The indicated usable capacity has been calculated considering the theoretical volume (without cooling), a maximum filling of 95% and a liquid density of 460 kg/m<sup>3</sup>

### SCHEMATIC DIAGRAM

- VG Gas phase filling valve
- VL Liquid phase filling valve
- VC Consumption valve
- VR Overflow valve
- PPR Pressure Build up Unit (PBU)
- VEP Input valve PBU
- VSP Output valve PBU
- VRA Pressure regulator
- F Filter
- VAG Auxiliary valve - Gas phase
- IN Level
- IP Manometer
- vn Level gate valve
- re By-pass valve
- ri Bottom level valve
- rs Top level valve
- TP Pressure transmitter (according to model)
- TN Level transmitter (according to model)
- CS 3-way valve (safety)
- VS Safety valve
- SL Line safety valve
- VA Pressure relief valve
- Pe Casing safety device
- Tv Vacuum connection
- Mv Vacuum gauge device

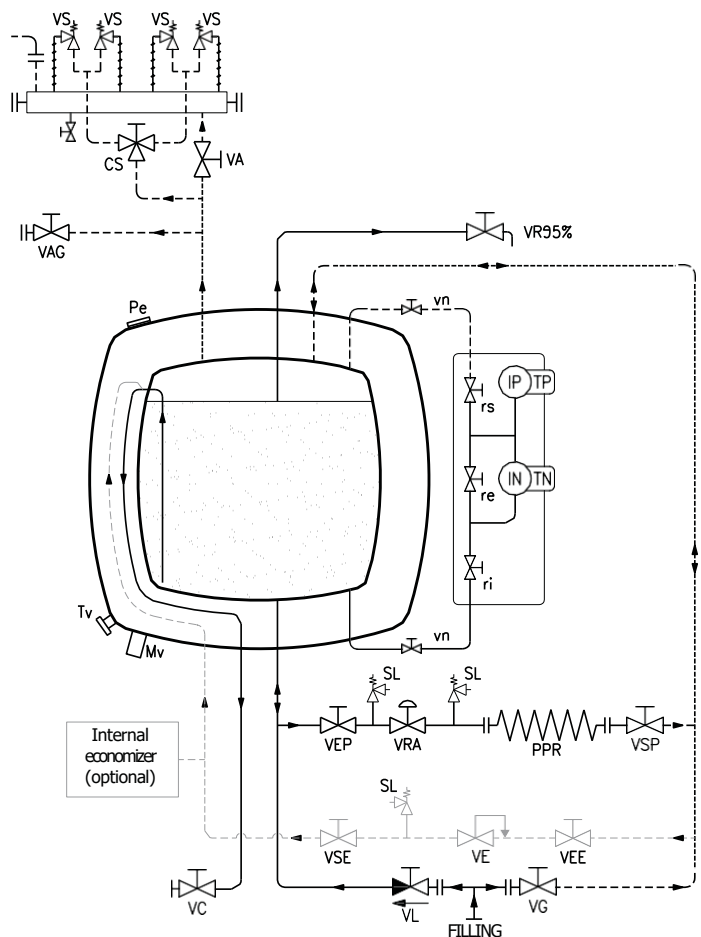

## GENERAL DIMENSIONS

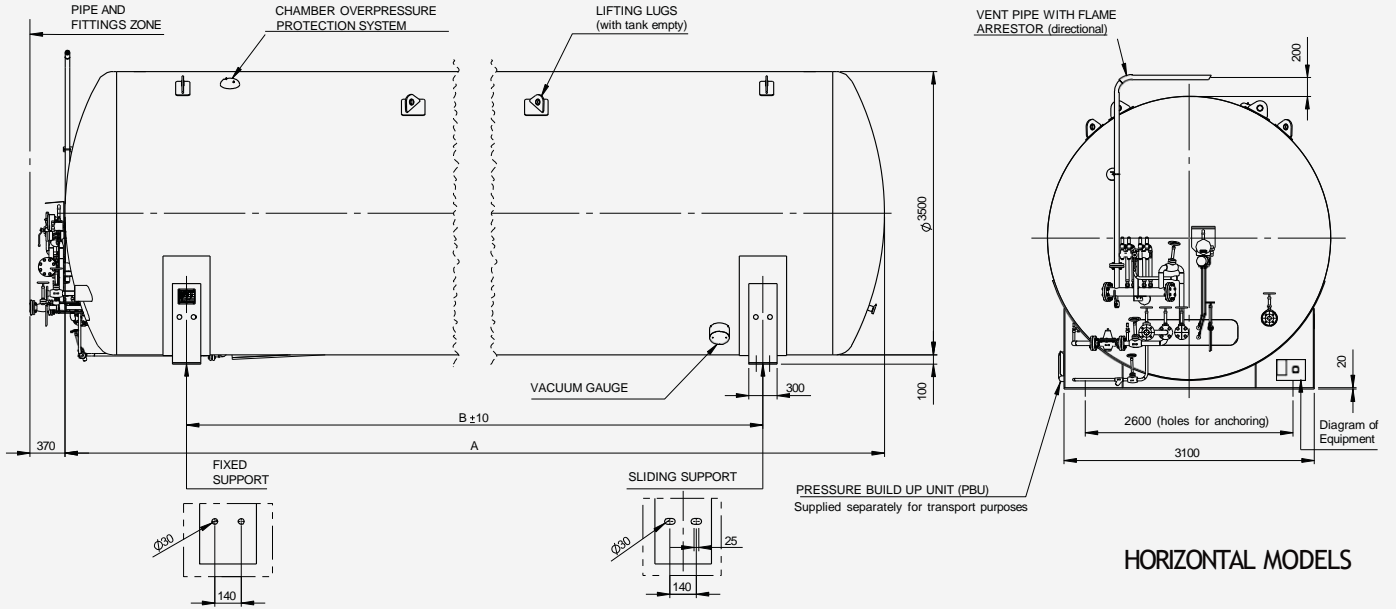

HORIZONTAL MODELS

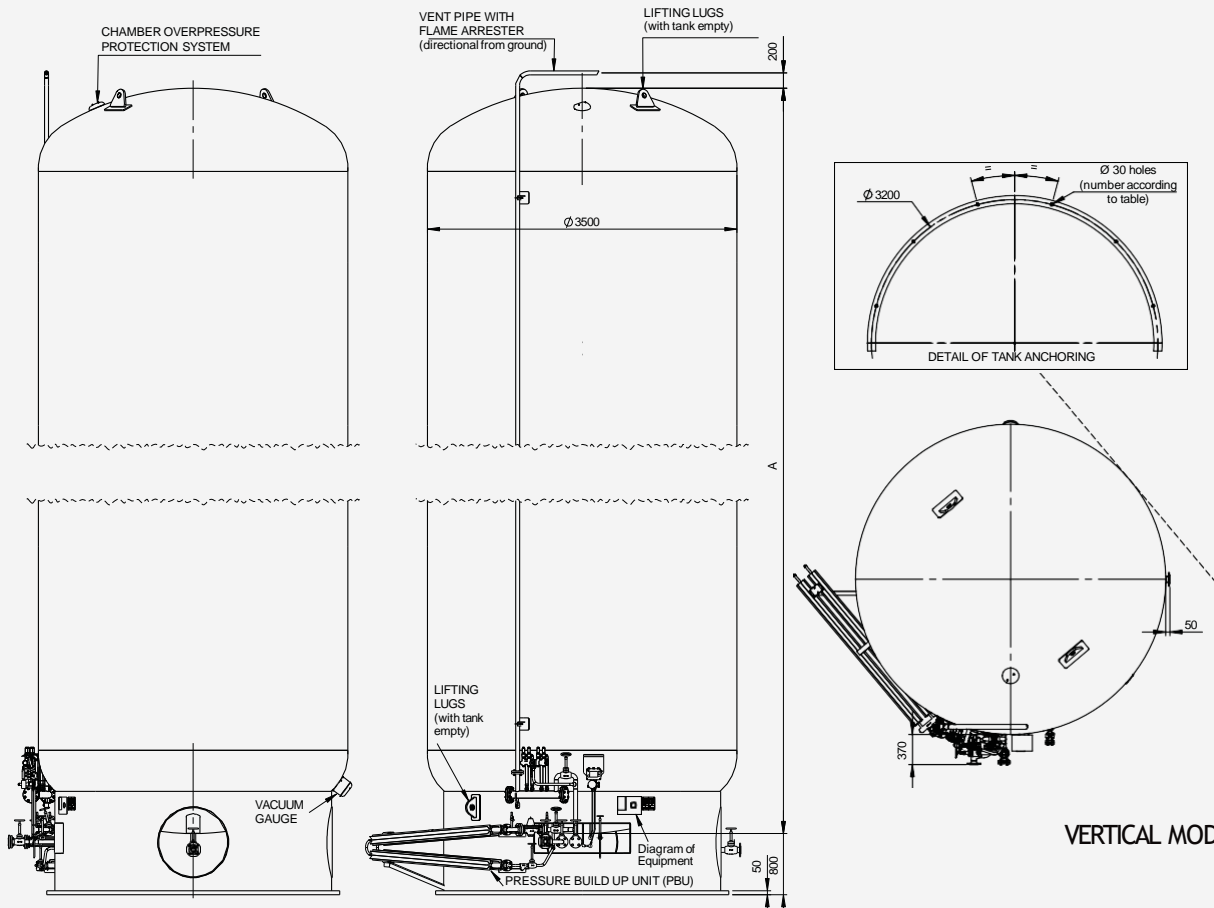

VERTICAL MODELS

## DIAMETER 3900

HORIZONTAL MODELS		LC107H39	LC120H39	LC130H39	LC150H39	LC200H39	LC226H39	LC245H39
Nominal volume	m <sup>3</sup>	107	120	130	150	200	226	245
Theoretical volume	m <sup>3</sup>	107,5	118,8	130,5	150,4	200,0	226,1	245,0
Usable capacity <sup>(1)</sup>	Tm	47,0	51,9	57,0	65,7	87,4	98,8	107,1
Length (A)	mm	13.092	14.372	15.692	17.892	23.384	26.292	28.392
Distance between supports (B)	mm	10.000	11.000	12.500	14.800	20.000	23.200	25.200
Theoretical tare (Tn)	Tm	28,0	30,5	32,9	37,9	47,6	54,1	58,3

VERTICAL MODELS		LC107V39	LC120V39	LC130V39	LC150V39	LC200V39	LC226V39	LC245V39
Nominal volume	m <sup>3</sup>	107	120	130	150	200	226	245
Theoretical volume	m <sup>3</sup>	107,5	118,8	130,5	150,4	200,0	226,1	245,0
Usable capacity <sup>(1)</sup>	Tm	47,0	51,9	57,0	65,7	87,4	98,8	107,1
Height (A)	mm	13.092	14.372	15.692	17.892	23.382	26.292	28.392
Theoretical tare (Tn)	Tm	28,6	31,1	33,6	38,7	48,6	55,2	59,5

PPR standard para consumo de 1000 Nm<sup>3</sup>/h a 3 bar (otras capacidades: 2000, 3000 y 4000 Nm<sup>3</sup>/h)

(1) The indicated usable capacity has been calculated considering the theoretical volume (without cooling), a maximum filling of 95% and a liquid density of 460 kg/m<sup>3</sup>

### SCHEMATIC DIAGRAM

- VG Gas phase filling valve
- VL Liquid phase filling valve
- VC Consumption valve
- VR Overflow valve
- PPR Pressure Build up Unit (PBU)
- VEP Input valve PBU
- VSP Output valve PBU
- VRA Pressure regulator
- F Filter
- VAG Auxiliary valve - Gas phase
- IN Level
- IP Manometer
- vn Level gate valve
- re By-pass valve
- ri Bottom level valve
- rs Top level valve
- TP Pressure transmitter (according to model)
- TN Level transmitter (according to model)
- CS 3-way valve (safety)
- VS Safety valve
- SL Line safety valve
- VA Pressure relief valve
- Pe Casing safety device
- Tv Vacuum connection
- Mv Vacuum gauge device

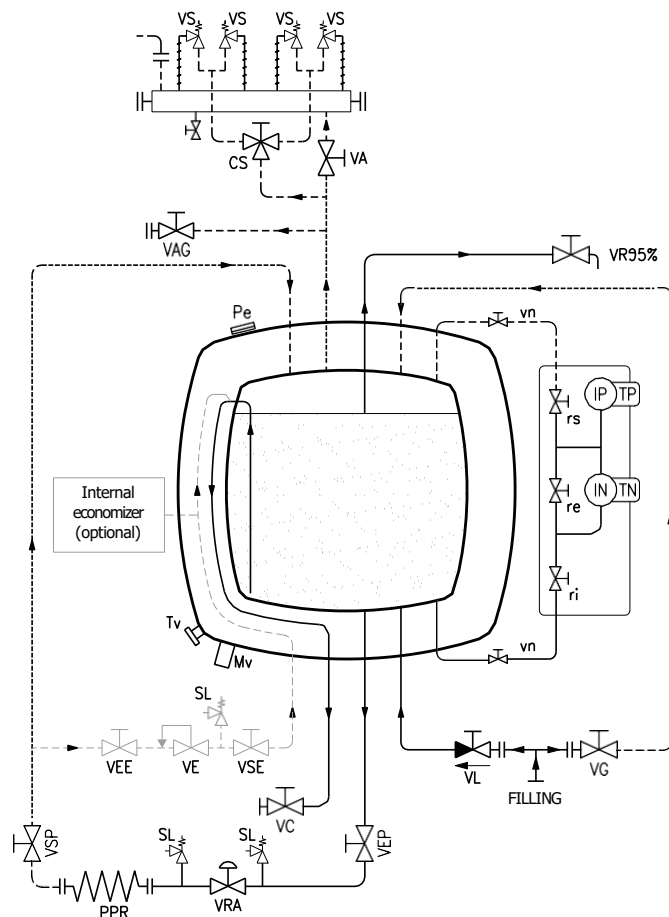



## DIAMETER 4200

HORIZONTAL MODELS		LC205H42	LC227H42	LC248H42	LC269H42	LC291H42	LC312H42
Nominal volume	m <sup>3</sup>	205	227	248	269	291	312
Theoretical volume	m <sup>3</sup>	205,5	226,8	248,1	269,5	290,8	312,1
Usable capacity <sup>(1)</sup>	Tm	89,8	99,1	108,4	117,8	127,1	136,4
Length (A)	mm	20.745	22.745	24.745	26.745	28.745	30.745
Distance between supports (B)	mm	17.500	19.500	21.500	23.500	25.500	27.500
Theoretical tare (Tn)	Tm	49,6	54,3	58,9	63,6	68,2	72,8

VERTICAL MODELS		LC205V42	LC227V42	LC248V42	LC269V42	LC291V42	LC312V42
Nominal volume	m <sup>3</sup>	205	227	248	269	291	312
Theoretical volume	m <sup>3</sup>	205,5	226,8	248,1	269,5	290,8	312,1
Usable capacity <sup>(1)</sup>	Tm	89,8	99,1	108,4	117,8	127,1	136,4
Height (A)	mm	20.745	22.745	24.745	26.745	28.745	30.745
Theoretical tare (Tn)	Tm	50,5	55,2	59,9	64,6	69,3	74,1

PPR standard para consumo de 1000 Nm<sup>3</sup>/h a 3 bar (otras capacidades: 2000, 3000 y 4000 Nm<sup>3</sup>/h)

(1) The indicated usable capacity has been calculated considering the theoretical volume (without cooling), a maximum filling of 95% and a liquid density of 460 kg/m<sup>3</sup>

### SCHEMATIC DIAGRAM

- VG Gas phase filling valve
- VL Liquid phase filling valve
- VC Consumption valve
- VR Overflow valve
- PPR Pressure Build up Unit (PBU)
- VEP Input valve PBU
- VSP Output valve PBU
- VRA Pressure regulator
- F Filter
- VAG Auxiliary valve - Gas phase
- IN Level
- IP Manometer
- vn Level gate valve
- re By-pass valve
- ri Bottom level valve
- rs Top level valve
- TP Pressure transmitter (according to model)
- TN Level transmitter (according to model)
- CS 3-way valve (safety)
- VS Safety valve
- SL Line safety valve
- VA Pressure relief valve
- Pe Casing safety device
- Tv Vacuum connection
- Mv Vacuum gauge device

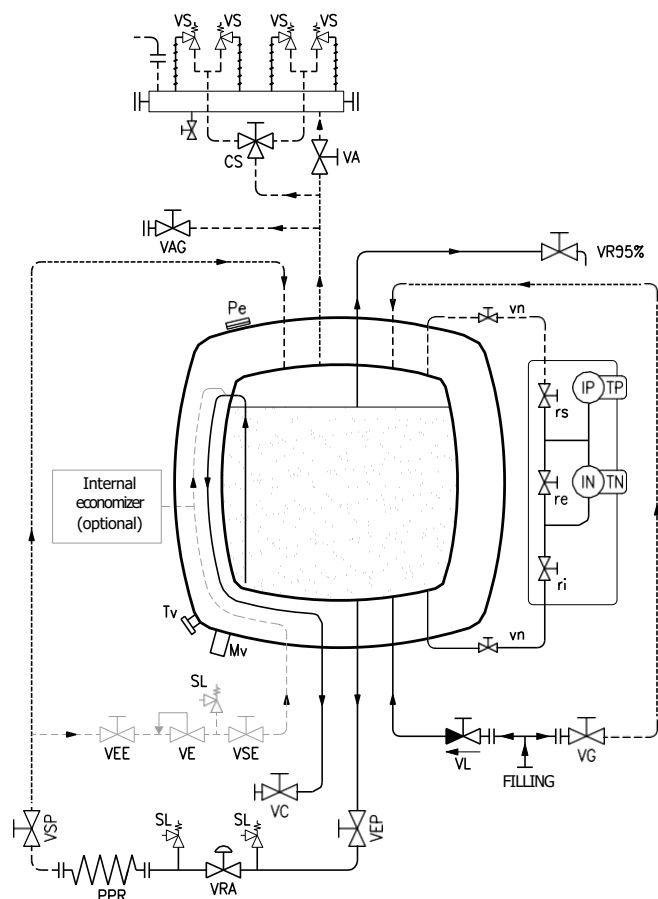

# Station Double Wall Storage Tank

## 500 CBM, Horizontal Type.

### DOUBLE WALL VACUUM INSULATED STORAGE TANK

HORIZONTAL TYPE – 500 m<sup>3</sup>

#### GENERAL ARRANGEMENT

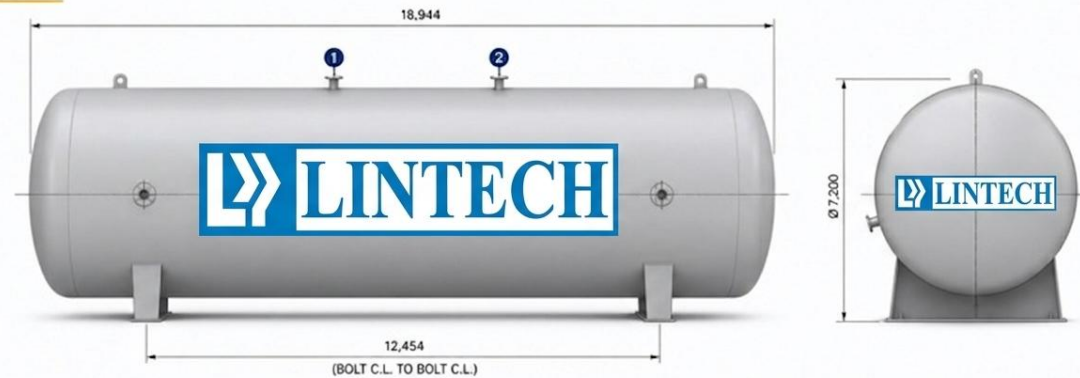

#### KEY FEATURES

- Double wall construction with high vacuum insulation for superior thermal performance
- Designed for cryogenic liquid storage with minimal boil-off loss
- Engineered and manufactured in accordance with ASME standards
- Robust saddle support for safe and stable installation
- Low heat ingress and long service life

#### GENERAL SPECIFICATIONS

Nit Capacity	500 m <sup>3</sup>
Design Pressure (Inner Vessel)	Up to 16 bar (1.6 MPa)
Design Temperature	-196 °C to +50 °C
Operating Medium	LNG or other Cryogenic Liquid (On Request)
Orientation	Horizontal
Insulation	High Vacuum with Perlite Insulation
Support Type	Saddle
Design Code	ASME BPVC Sec. VIII, Div. 2

Note: Dimensions are in mm. For reference only. Final design may vary based on project requirements.

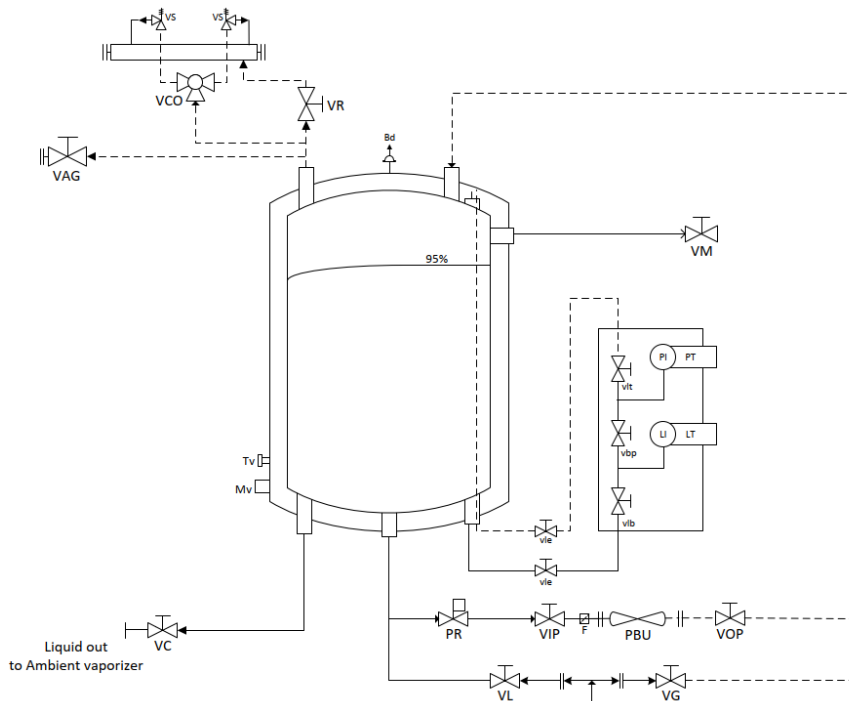

Legend	Function
VG	Gas Valve
VL	Liquid Valve
VC	Consumption valve
VM	Maksimum Valve
VIP	Inlet PBU Valve
PBU	Pressure Build Up
PR	Pressure Regulator
VOP	Outlet PBU Valve
F	Filter
VAG	Gas Phase Auxiliar Valve
VCO	Change Over Valve
VR	Relief Valve
VS	Safety Valve
vle	Level Valve
vlt	Level Top Valve
vib	Level Bottom Valve
vbp	By-pass Vlave
PI	Pressure Gauge
LI	Level
PT	Pressure Transmitter
LT	Level Transmitter
Pv	Vacuum Pump
Sv	Vacuum Sensor
Bd	Bursting Disk for Outer Tank

# Double Wall Storage Tank 6 x 850 CBM for Carrier Ship-Horizontal Type

## DOUBLE WALL VACUUM INSULATED STORAGE TANK

HORIZONTAL TYPE – 850 m<sup>3</sup>

### GENERAL ARRANGEMENT



Note: Dimensions are in mm. For reference only. Final design may vary based on project requirements.

### KEY FEATURES

- Double wall construction with high vacuum insulation for superior thermal performance
- Designed for cryogenic liquid storage at carrier ships with maximum holding time
- Including accessories inner tank to prevent sloshing
- Engineered and manufactured in accordance with ASME standards
- Robust saddle support for safe and stable installation
- Low heat ingress and long service life

### GENERAL SPECIFICATIONS

Net Capacity	850 m <sup>3</sup>
Design Pressure (Inner Vessel)	Up to 16 bar (1.6 MPa)
Design Temperature	-196 °C to +50 °C
Operating Medium	LNG or other Cryogenic Liquid (On Request)
Orientation	Horizontal
Insulation	High vacuum with MLI or Perlite Highinsulation
Support Type	Saddle
Design Code	ASME BPVC Sec. VIII, Div. 2

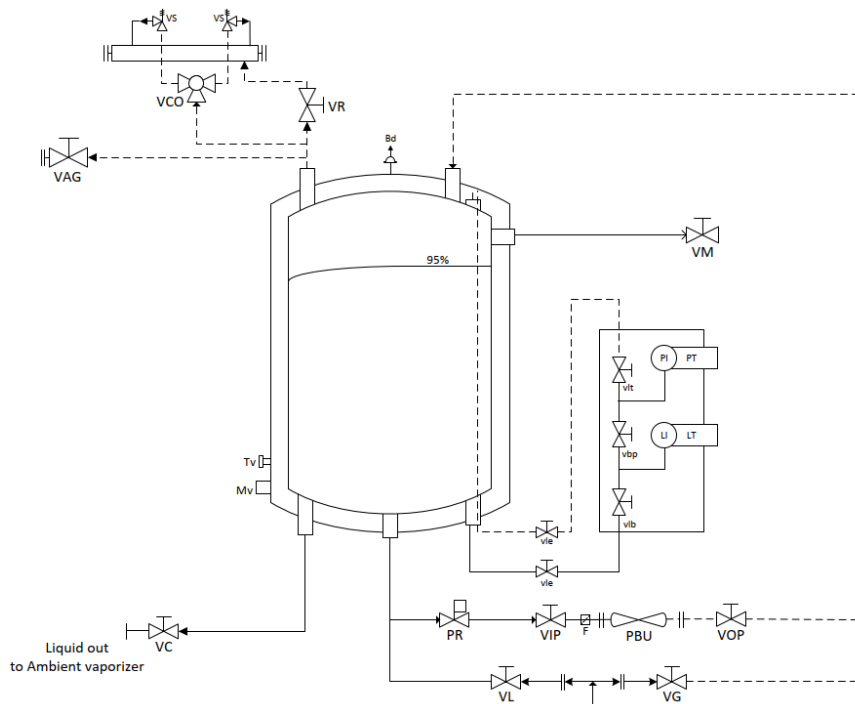

Legend	Function
VG	Gas Valve
VL	Liquid Valve
VC	Consumption valve
VM	Maksimum Valve
VIP	Inlet PBU Valve
PBU	Pressure Build Up
PR	Pressure Regulator
VOP	Outlet PBU Valve
F	Filter
VAG	Gas Phase Auxiliar Valve
VCO	Change Over Valve
VR	Relief Valve
VS	Safety Valve
vle	Level Valve
vlt	Level Top Valve
vlb	Level Bottom Valve
vbp	By-pass Vlave
PI	Pressure Gauge
LI	Level
PT	Pressure Transmitter
LT	Level Transmitter
Pv	Vacuum Pump
Sv	Vacuum Sensor
Bd	Bursting Disk for Outer Tank

## GENERAL DIMENSIONS

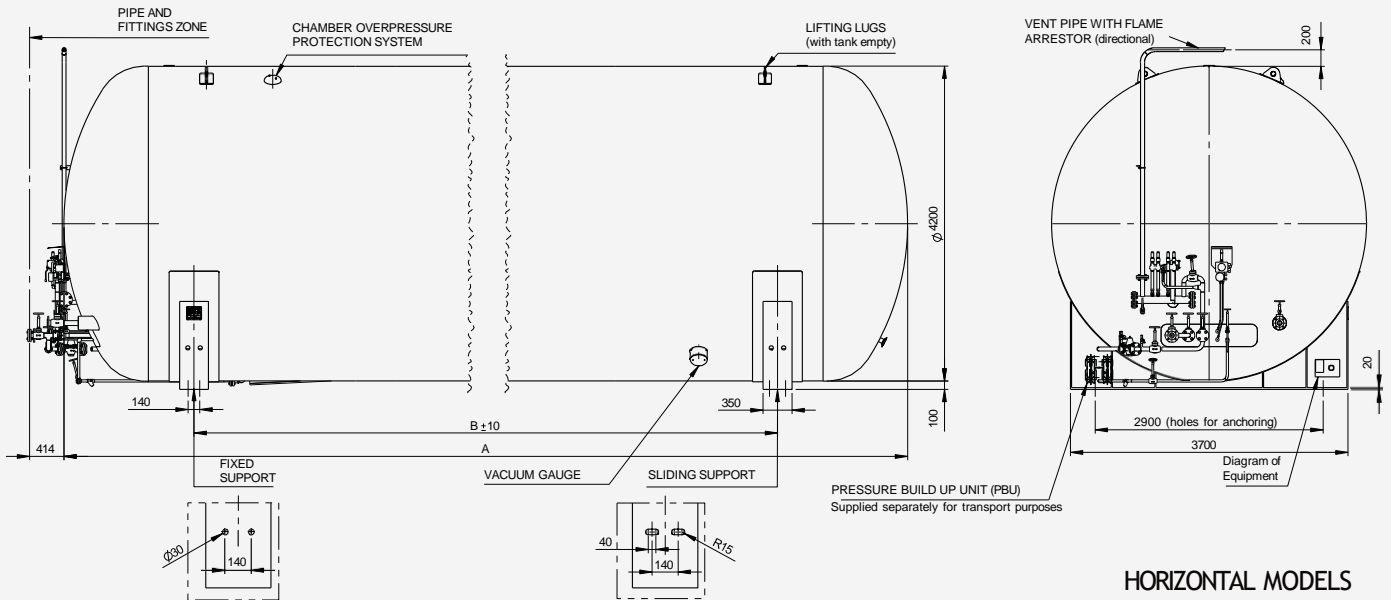

HORIZONTAL MODELS

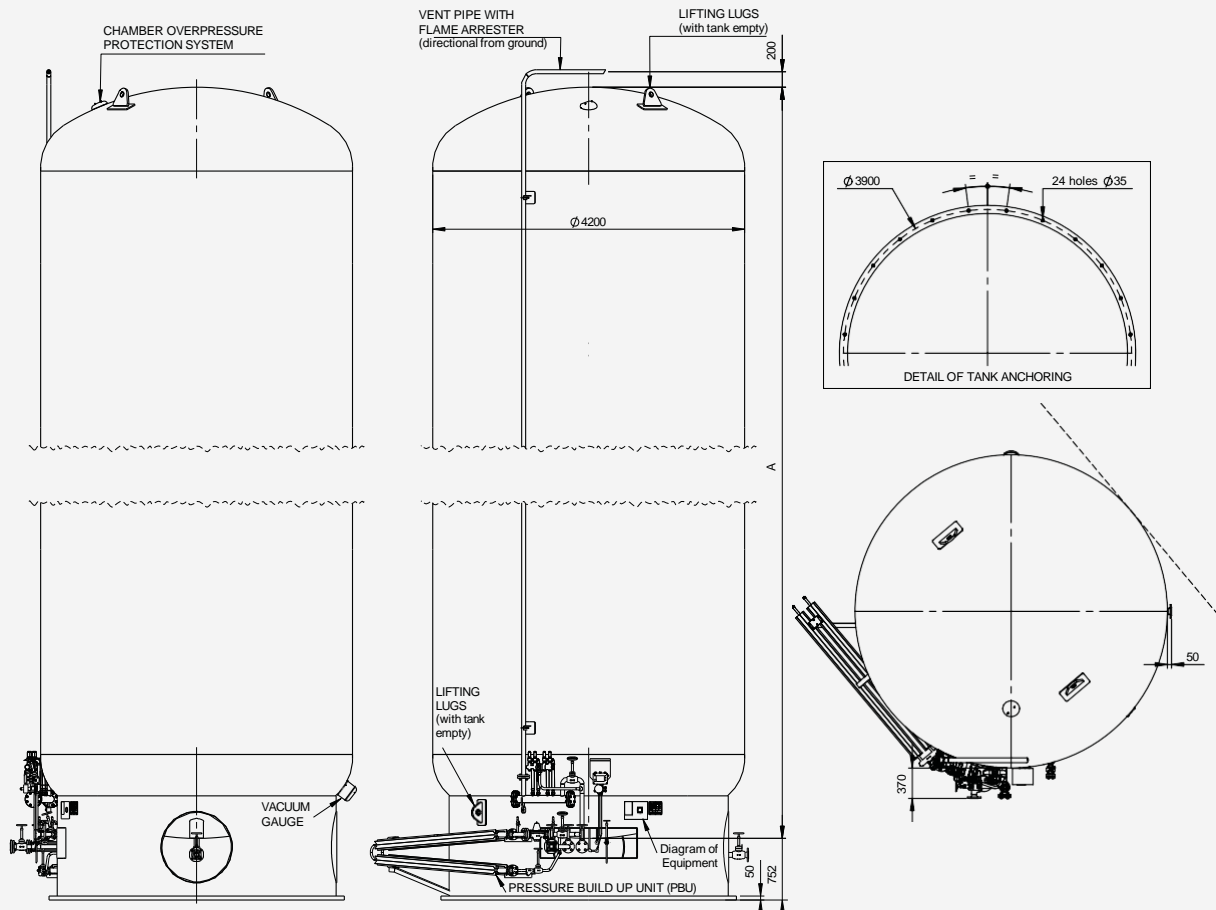

VERTICAL MODELS

### LC GNV

*Tanks for the supply of natural gas for vehicles at Service Stations, for CNG (compressed natural gas) and LNG (liquefied natural gas) or both at the same time.*



### GENERAL CHARACTERISTICS

- Tanks designed and adapted to the needs and characteristics of each individual supply station.
- Tanks adapted to the supply plant design, incorporating all the necessary outputs and connections for each function:
  - LNG connection.
  - CNG connection.
  - Pump returns, saturation return.
  - Extra connections for consumption at the station itself...
- Standard design pressure 18 bar. Other values of design pressure available upon request.
- PBU standard for consumption of 1000 Nm<sup>3</sup>/h at 14 bar.
- Tanks with “cold converter” or “thermosiphon” system.
- Compliance to norms ISO 16923 and ISO 16924, compliance to Gas Regulations.

(Optional) refrigeration coil to avoid boil-off.

***Consult us about your project requirements!***



**LTCC..\***

*Cryogenic tank-container for transporting liquefied natural gas LNG (UN 1972), methane (UN 1972), ethane (UN 1961), ethylene (UN 1038), nitrogen (UN 1977), with cryogenic insulation, cryogenic vacuum insulation and non-compressible insulating material.*

**GENERAL CHARACTERISTICS**

- Tank-container for transporting cryogenic liquefied gas.
- Thermal insulation with high vacuum and multilayer.
- Container type: 1AA according to ISO 668.
- Applicable European Directives: 2010/35/EU (Pi marking), 2008/68/EC.
- Standards applied: ADR, RID, ISO, CSC, IMDG, EN13530.
- Valid for transport with partial loads.
- Number of compartments: 1.



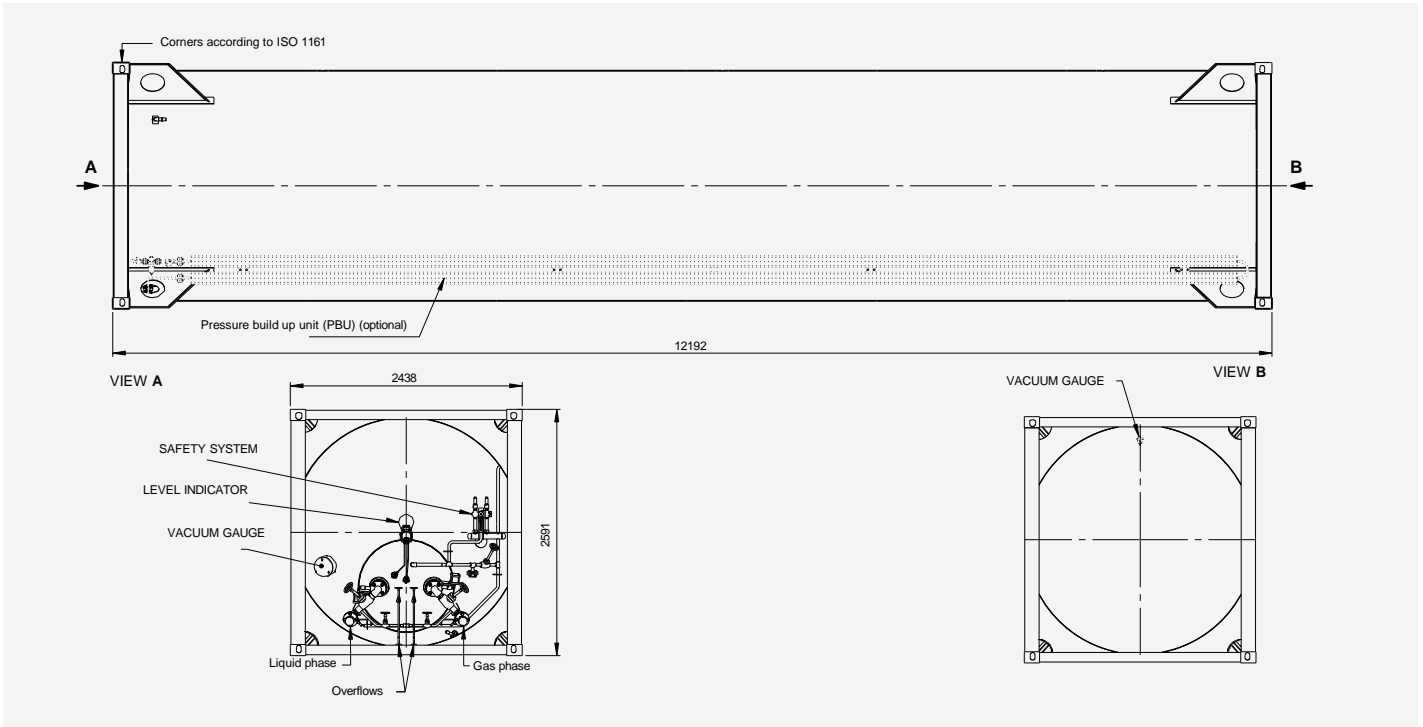

## ISO-CONTAINER DESIGN DATA<sup>(1)</sup>

- Geometric capacity: 46,5 m<sup>3</sup>.
- Maximum working pressure: 9 bar.
- Working temperature: -196, +50 °C.
- Empty weight: approximately 9,5 tons.

## FINISHES

- PRIMER: Polyamide epoxy (60 microns).
- TOP COAT: White polyurethane (60 microns).  
Total thickness: 120 microns.
- INTERIOR: Particle-free and dry.

## EQUIPMENT AND FEATURES

- Connectors for filling and emptying according to client needs
- Manual stopvalves, globe type, with extended spindle for cryogenic use
- Bottom valves with pneumatic actuation, CAEN-type, with non-return feature
- Two overflow pipes according to client needs.

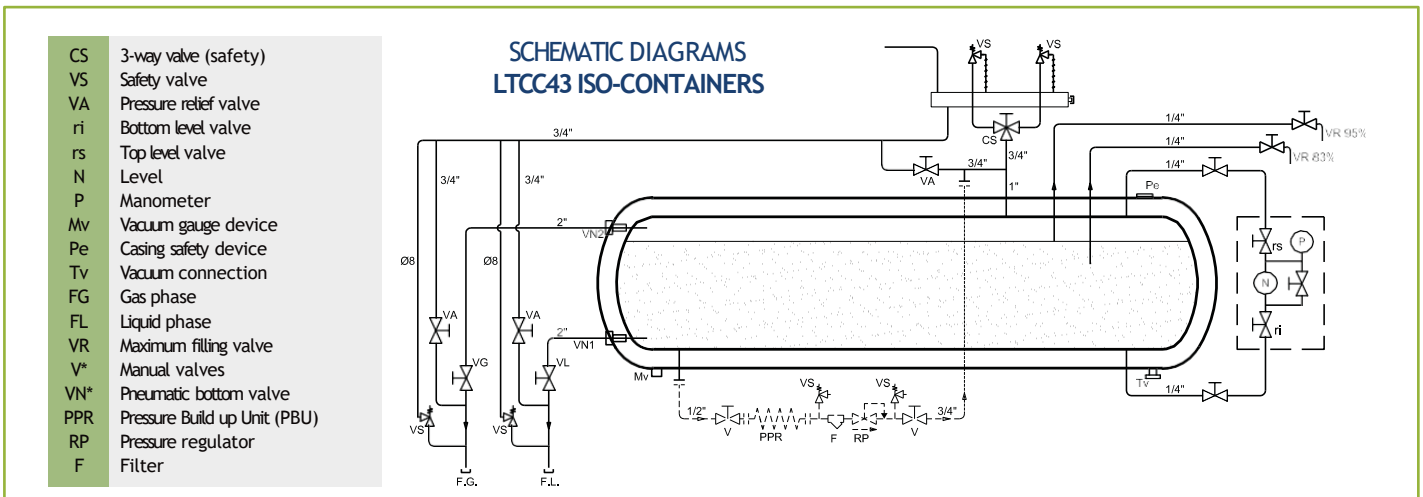

(1) Design data corresponding to one of the standard Lapesa LNG iso-container.

### LCUA 1000 V

*Cryogenic skid unit for liquefied natural gas LNG (UN 1972), methane (UN 1972), ethane (UN 1961), ethylene (UN 1038), nitrogen (UN 1977).  
EC marking (Directive 2014/68/EU).*



#### GENERAL FEATURES

- “Plug and play” equipment.
- EC marking (Directive 2014/68/EU).
- Geometric volume: 1,000 litres.
- Maximum allowable pressure: 10 bar (other pressures available upon request).
- Approximate weight: 1,200 kg.
- Modular.
- Insulation system: perlite in vacuum chamber.
- Easy to transport vertically on truck. 192 x 92 mm orifices for handling with forklift, when empty.
- Good use of space.

#### FITTINGS INCLUDED

- Pressure build-up unit (PBU).
- Environmental gasifier to consumption.
- Auxiliary gas phase connection.
- Economiser.
- ND40 flame arrester, directional and detachable.
- “Teledyne” type vacuum gauge.
- Media 05 (Samson) type level and pressure indicator. Options: electric, with level transmitter and pressure transmitter.

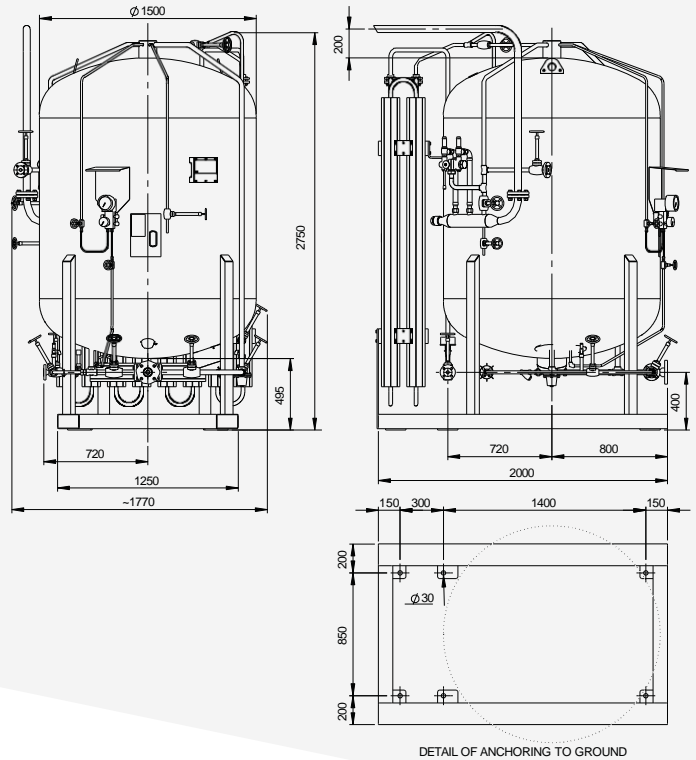
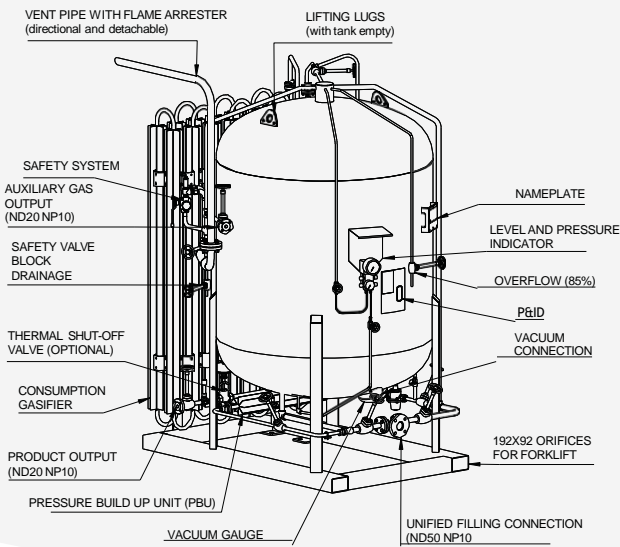

### MODULAR EQUIPMENT

- STD 35 Nm<sup>3</sup>/h ambient gasifier. (Extendable to 70 Nm<sup>3</sup>/h and 105 Nm<sup>3</sup>/h). Possibility of extending after installation.\*
- Elevated frame.
- PBU: 1/2" input/output piping. Max. capacity 100 Nm<sup>3</sup>/h at 3 bar (extendable at request).
- Filling lines.
- 1/2" economiser and economiser-regulator valve.
- ND20 auxiliary gas phase connection. (Optional temperature controlled shut-off valve).
- Safety: Flame arrester; double safety valve; 3-way valve; discharge manifold with drainage system and manual drainage valve.

(\*) Gasification capacity can be increased by including more powerful gasification modules.

VG	Gas phase filling valve
VL	Liquid phase filling valve
VC	Consumption valve
VR85	Overflow valve 85%
PPR	Pressure Build up Unit (PBU)
VEP	PBU input valve
VSP	PBU output valve
RP	Pressure regulator
F	Filter
VAG	Gas phase auxiliary valve
IN	Level
IP	Manometer
vn	Level gate valve
re	By-pass valve
ri	Bottom level valve
rs	Top level valve
TP	Pressure transmitter (according to model)
TN	Level transmitter (according to model)
CS	3-way valve (safety)
VS	Safety valve
SL	Line safety valve
VA	Pressure relief valve
Pe	Casing safety device
Tv	Vacuum connection
Mv	Vacuum gauge device
VRE	Economiser regulator valve
VSE	Economiser output valve
VSD	Tank output valve

### SCHEMATIC DIAGRAM LNG SKID LCUA 1000 V

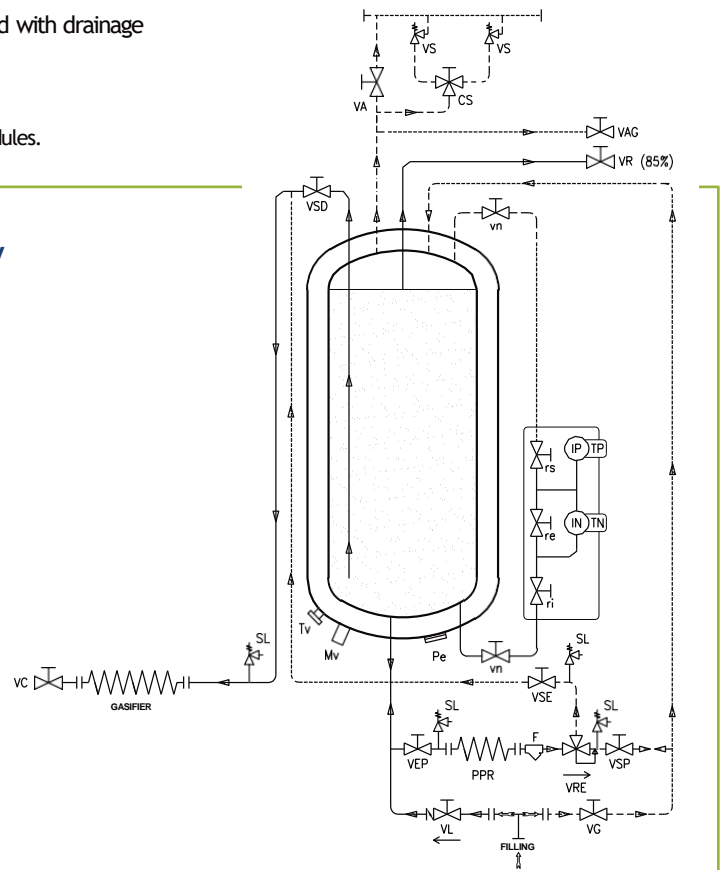

## LNG TANKERS

TANKER FOR THE TRANSPORT AND SUPPLY OF LNG

### LTC58

*Cylindrical cryogenic tanker for the transport and supply of LNG, 58 m<sup>3</sup> capacity, 44 TN MAM chassis.*

#### CHARACTERISTICS STANDARD TANKER

- Products to be transported: cryogenic liquefied gases class 2:  
LNG (UN1972), methane (UN1972), ethane (UN1961), ethylene (UN1038), etc.
- Manufactured according to applicable European Directives:  
2010/35/UE (Pi marking), 2014/103/UE.
- Application norms: ADR, EN13530, IM08 (optional).
- Maximum working pressure: 3 bar.
- Design temperature: -196 °C + 50 °C.
- Inner tank material: Austenitic stainless steel.
- Thermal insulation multilayer with high vacuum.
- Finishing with anticorrosive primer (high grade cathaphoresis for chassis) and white polyurethane (blue color for chassis).



*We adapt to the needs of our clients.*

Shown is an example of our standard tanker. Other options available upon request.

# LNG TANKERS

## TANKER FOR THE TRANSPORT AND SUPPLY OF LNG

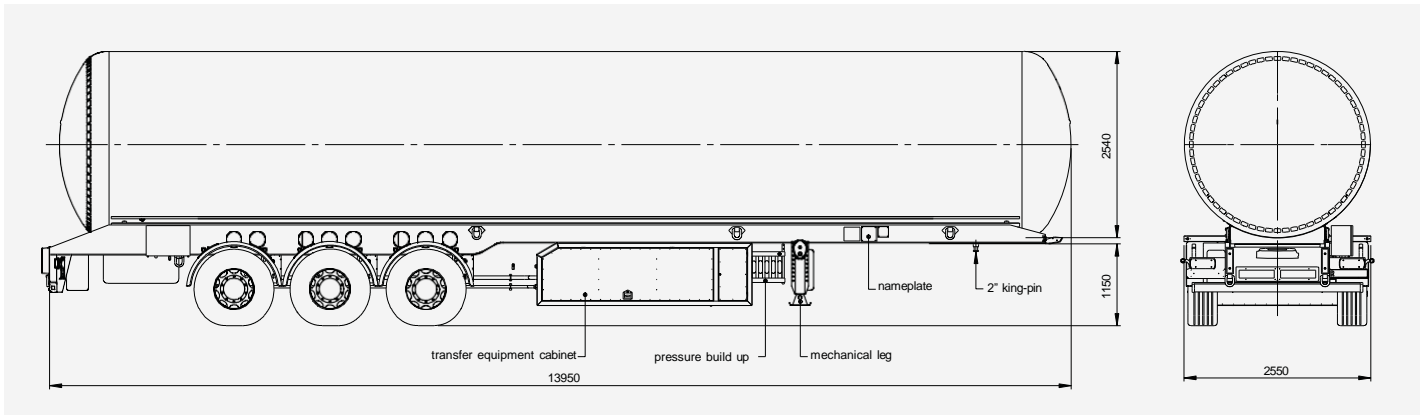

### ELEMENTS INCLUDED IN STANDARD TANKER

- Internal baffles for partial loads.
- Cabinet in central area, accessible from either left or right side.
- Rolling unit characteristics:
  - Three axles (two wheels per axle) with 20" bushing.
  - King-pin 2".
  - Pneumatic suspension.
  - Full frame, for optimal and long-lasting weight distribution.
  - Axles SAF or similar.
  - Aluminum rims.
  - ADR electrical installation.
  - Parking brake with 2 axis pneumatic actuators.
  - EBS brakes S2/SM. Disc brake 430 x 45.
  - Axis-type elevator.
  - Telescopic mechanical feet.
  - Rubber mudguards, keys for wheels, aluminum rear anti-embedment device, toolbox, two fire-extinguishers with box, etc.
  - Others: please consult.

### GENERAL DIMENSIONS FOR A 44 TON TANKER

- Nominal capacity: 58 m<sup>3</sup>.
- Approximate tanker empty weight: 12,5 tons.
- Approximate loading capacity (assuming 7,5 ton tractor head):
  - 24 tons (total 44 ton).
  - 23 ton (with LNG 3 bar at 95%).
  - 21 ton (with LNG 0 bar at 89%).

### LNG EQUIPMENT

- Discharge pump.
- Pressure elevator.
- Volumetric counter.
- Cabinet with door.
- Mechanical level indicator by differential pressure.
- Internal bottom valves with non-return feature included.
- Cryogenic stopvalves.
- Pressure relief valves in pipes, manual and automatic, connected to vent pipe.
- P&ID adapted to client needs.



#### SCHEMATIC DIAGRAM LTC58 LNG TANKER

CS	3-way valve (safety)
VS	Safety valve
VA	Pressure relief valve
ri	Bottom level valve
rs	Top level valve
N	Level
Mv	Vacuum gauge device
Pe	Casing safety device
Tv	Vacuum connection
FG	Gas phase
FL	Liquid phase
VR	Maximum filling valve
V*	Manual valves
VN*	Pneumatic bottom valve

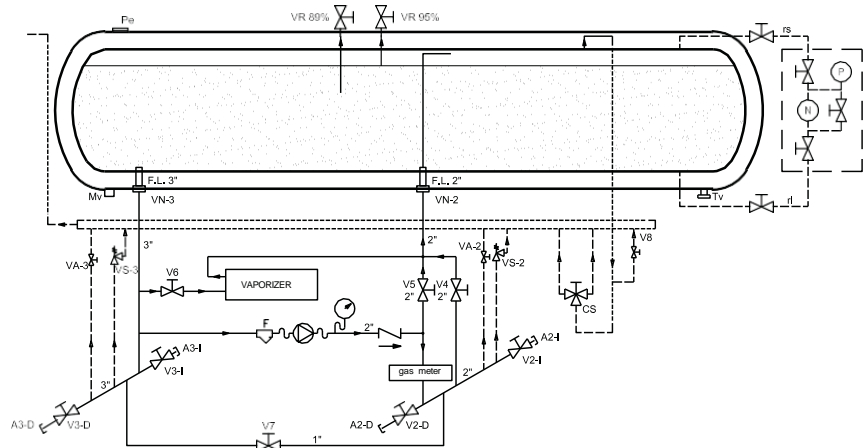

#### SAFETY/EMERGENCY SYSTEMS

- The tankers include **6 emergency pushbuttons**, distributed in various places. When manually actuated, they close the bottom valves of the tanker and the pump enters stop mode.
- **Closed cabinet detector.** When the transfer cabinet is closed, the bottom valves stay closed and the pump enters stop mode.
- **Parking brake.** The bottom valves can only be opened when this brake is activated.
- **Anti-start system.** If the driver starts driving with the cabinet open, the system acts on the brakes, braking the tanker. The system does not act when speed is higher than 5 km/h.
- **Safety valves** against LNG overpressure, with manifold.

#### HYDRAULIC INSTALLATION

- For the correct operation of the hydraulic circuit that feeds the LNG pump, the tractor head must include a power supply, hydraulic pump, oil tank, refrigeration system, etc...

#### FINAL DOCUMENTATION

- Manufacturing dossier
- ADR documentation
- Instructions manual
- Technical drawing
- Full documentation about vehicle homologation

#### EXAMPLES OF OPTIONAL ELEMENTS

- Inertizing
- IMO 8 (allows the transport of the tank on short distances)
- Finishing with client logo
- Different brands for the equipment
- Extras for rolling unit:
  - Polished rims
  - Third axle auto-directional
  - Integral LED lights
  - Weight distribution

